

TRACEPAK® INSTRUCTIONS

Contents

	Page
Installing TRACEPAK Tubing Bundles	1-4
Model Numbers	5-6
Tubing Specifications	7-8
Heating Specifications	9
Connection Kits	10
Termination Kits	11
Sealing	12-13
Heat Shrink Boot End Seals (TPKHS)	12
Enclosure Entry Seals (TPKES)	12
Silicone End Seal (TPKSK)	13
Jacket Patch Kit (TPKJP-1, TPKJP-2)	13
High Temperature Jacket Kit (TPKJP-3, TPKJP-4)	13
Line Sensing Thermostat	14

TRACEPAK

Installation instructions are provided to give the field engineer and installers the necessary information to install TRACEPAK in an efficient and effective manner. These recommendations are suggestions and do not imply that only these methods can be used.

Caution: All installations must be done in accordance with applicable local codes. To satisfy code and approval agency requirements O'Brien Power Connection and End Termination Kits must be used.

Approvals and product warranty may be void if alternate connection kits are used or installation instructions and proper end sealing are not followed.

Receiving

- Ensure that the protective caps placed over the ends of the bundle are firmly in place.



Storage

- All bundle ends must be sealed at all times. (See "Sealing the Ends.")
- Cover from weather.
- Protect from mechanical damage.
- Temperature Range

Electrically Traced Products

-40°F (-40°C) 140°F (60°C)

Steam Traced Products

With TPU Jacket: -60°F (-50°C) to 140°F (60°C)

With SV47 Jacket: -40°F (-40°C) to 140°F (60°C)

Determining Required Length and Routing

- Seal all ends of the tubing bundle during installation. (See "Sealing the Ends.")
- Route along existing structures such as beams and columns to provide support.
- Avoid areas where the ambient temperature may exceed 110°F (45°C).

- Maintain 1/2" (12mm) space between bundles.
- Measure square into corners. (The length of TRACEPAK® required to make a 90 degree bend is about 13" (330mm). Measuring square into the corner will give you 16" (410mm). The extra 3" (80mm) is part of your safety factor to ensure you have enough length.)
- Allow 12" - 18" (300mm to 450mm) of straight tubing bundle before connecting to fittings. Add enough length to TPH and TPL bundles to connect the tracer to the supply connection and to the return system.
- Add enough length to TPE bundles to connect the power supply. Include the length from the process connection locations to the junction box and 6" (150mm) inside the junction box. Include the required length of tracer to heat valves or other equipment at the end of the bundle.

Caution: Electric Traced Systems Consult the installation instructions for the tracer. You may be required to make connections and terminations at a particular point on the tracer. If so, you will need to locate these points before cutting the bundle to its final length. Failure to properly install the electric tracer can lead to excessive heating, tracer failure and damage to the tubing bundle.

Supporting

- Supports and hangers must have a large surface area and be designed so they can not be over-tightened to crush the tubing bundle. Do not use U-bolts as supports.
- Angle iron may be used as a support. Place the bundle in an angle sized 1/2" (12mm) larger than the largest dimension of the bundle and secure it with metal or plastic straps. Do not use wire ties.
- Cable tray may be used as a support. Maintain a minimum of 1/2" (12mm) space between bundles.
- Maximum Support Centers
Horizontal Runs - 6 feet (2 meters)
Vertical Runs - 15 feet (5 meters)



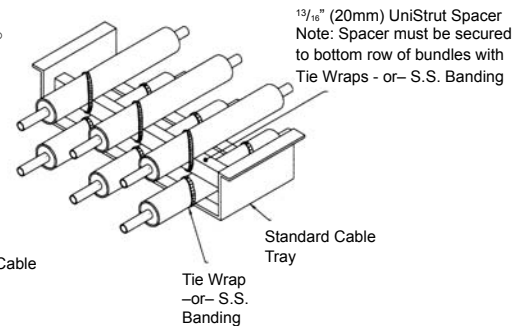
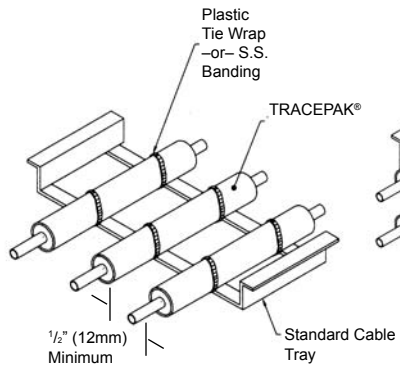
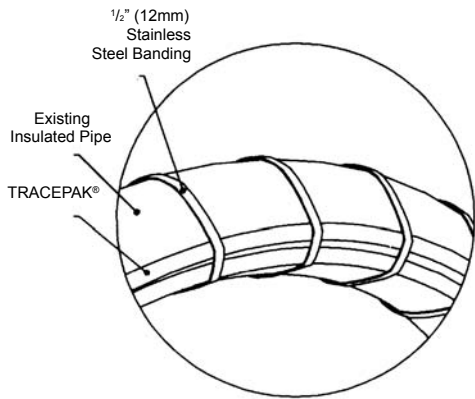
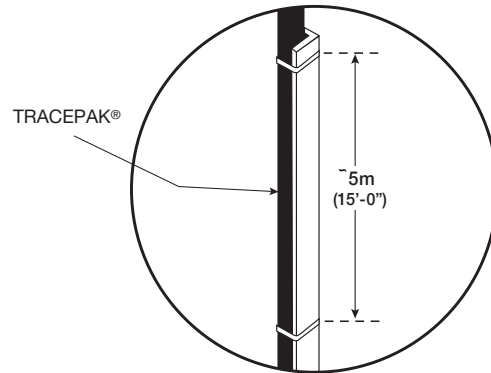
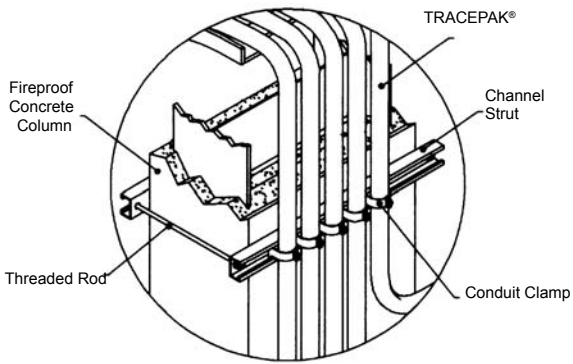
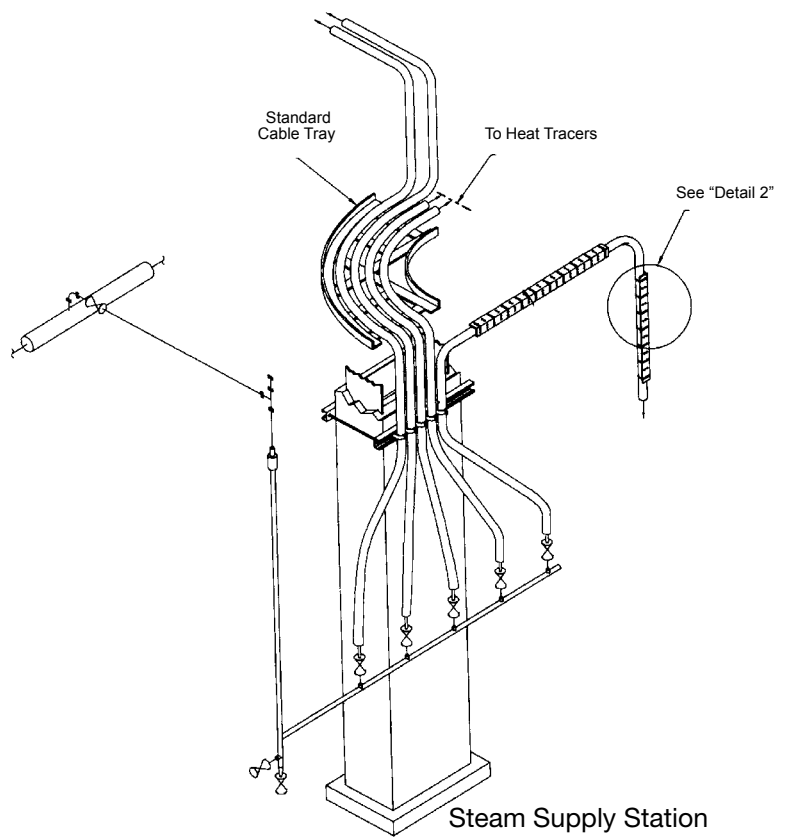
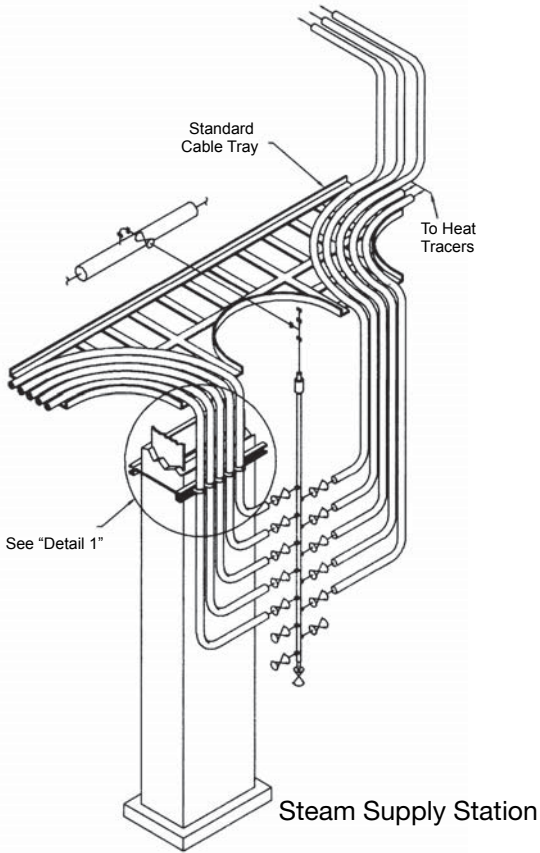

Uncoiling and Straightening

Method 1 - Roll it out on the floor or other flat surface.
This will leave a slight bow that can be taken out by hand.



Method 2 - Use a second smaller spool to straighten the product as it is taken off of the larger shipping spool.

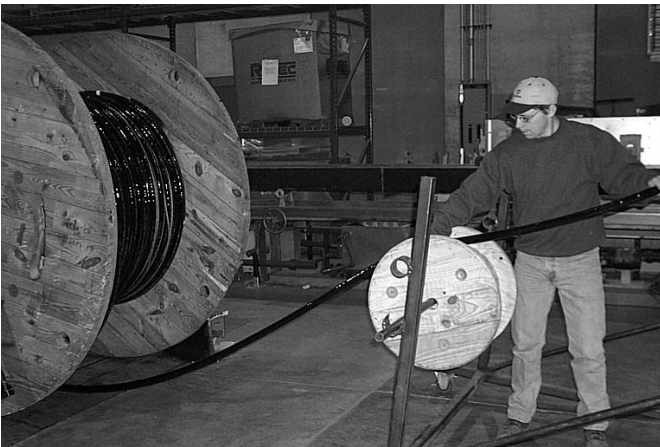

Bending

- The jacket will wrinkle when the bundle is bent. This is a normal condition and does not affect the performance or life of the bundle.
- Do not exceed the minimum bending radius of 8" (200mm).
- Use the O'Brien Bundle Bending Tool or a mandrel with the minimum bending radius such as a small spool.
- Bend on the small dimension. The bundle will tend to twist and then bend on this dimension naturally.

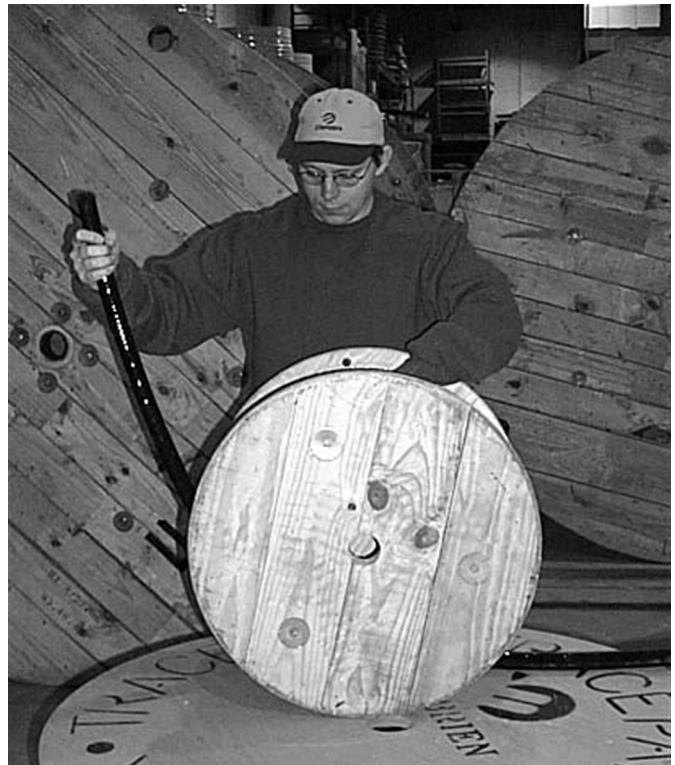

Sealing the Ends

- All ends of the bundle must be sealed temporarily during installation. Use a plastic bag and tape it in place to seal the end of the bundle.
- TPKSK Silicone sealant – see page 13
- TPKHS Heat shrink boots – see page 12
- TPKJP Jacket patch – see page 13
- TPKES Entry Seal – see page 12

To bend on the other (larger) dimension:

Method 1 - Make two back to back bends on small dimension and twist the bundle in the direction you want it to go.



Method 2 - Grasp the bundle firmly and twist it 90°.

Then make the bend. This technique may also be used to position the tubing for process connection.



Process Connections with O'Brien Centerline Tool

- Allow enough bundle length to connect steam to supply/return or the electric tracer to the power supply junction box/termination kit.

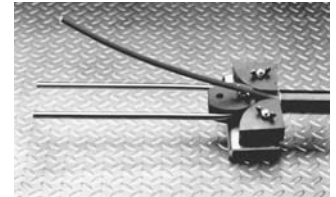
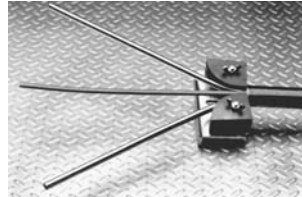

- Make the required tubing bends with a tubing bender or the O'Brien 2 1/8" (54mm) Centerline Tool before sealing the end of the bundle.
- Permanently seal the end of the bundle. Install boots before cutting tubes to length.

Tracer Connections

- Electric tracers must be connected and terminated using approved power connection and termination kits. See page 10 & 11.
- When determining the length of the bundle, be sure to add enough length to bring the electric tracer into the junction box or the steam tracer to the supply and/or return connection. (See caution for electric tracer systems under Determining Required Length and Routing.)

Temperature Control

Many installations do not require secondary temperature control. When temperature control is required the following accessories are offered.

- **TPKTS-B-7** Line Sensing Thermostat, NEMA 7 Housing, 22 amp 125/250 VAC.
- **TPKTS-EX-02** Line Sensing Thermostat, CENELEC standards approved EEx d IIC T6, 22 amp 250VAC.
- **TPKTS-A-7** Ambient Sensing Thermostat, NEMA 7 Housing, 22 amp 125/250 VAC.
- **TPKTS-EX-04** Ambient Sensing Thermostat, CENELEC standards approved EEx d IIC T6, 22 amp 250 VAC.

If a line sensing thermostat is used see page 13 for instructions on field installation of the temperature sensor.

Labeling

Labeling requirements for electric traced piping systems are determined by the prevailing code governing the installation. The installer is cautioned to comply with the unique labeling requirements of the governing code before completion of the installation.

TRACEPAK MODEL NUMBER



Tracepak Model Number X = Alpha # = Numeric	Description																																																																
X	Unit of measure – only used for bundle sold and marked in Meters No prefix designates product is sold and marked in feet M = meters																																																																
/	Separator																																																																
T	Tracepak Product Designation																																																																
P	This location in the model number will indicate the maximum exposure temperature and duration (continuous or intermittent.) Standard exposure will be assigned a P. Standard exposure is defined as any non-isolated bundle or any bundle with a temperature rating of no more than 400F. Exception to this; bundles with a rating higher than 400F but for maintain only. <u>Any temperature rating other than the exact temperatures shown below will be assigned a Z.</u> Standard exposure P <table style="margin-left: 40px; border: none;"> <tr> <td></td> <td style="text-align: center;">Steam and Continuous</td> <td style="text-align: center;">Intermittent Add 'N' to temperature designation</td> <td style="text-align: center;">One Minute MAX Add 'S' to temperature designation (020730)</td> </tr> <tr> <td>450F/230C</td> <td style="text-align: center;">A</td> <td style="text-align: center;">AN</td> <td style="text-align: center;">AS</td> </tr> <tr> <td>500F/260C</td> <td style="text-align: center;">B</td> <td style="text-align: center;">BN</td> <td style="text-align: center;">BS</td> </tr> <tr> <td>550F/290C</td> <td style="text-align: center;">C</td> <td style="text-align: center;">CN</td> <td style="text-align: center;">CS</td> </tr> <tr> <td>600F/315C</td> <td style="text-align: center;">D</td> <td style="text-align: center;">DN</td> <td style="text-align: center;">DS</td> </tr> <tr> <td>650F/345C</td> <td style="text-align: center;">F</td> <td style="text-align: center;">FN</td> <td style="text-align: center;">FS</td> </tr> <tr> <td>700F/370C</td> <td style="text-align: center;">G</td> <td style="text-align: center;">GN</td> <td style="text-align: center;">GS</td> </tr> <tr> <td>750F/400C</td> <td style="text-align: center;">J</td> <td style="text-align: center;">JN</td> <td style="text-align: center;">JS</td> </tr> <tr> <td>800F/425C</td> <td style="text-align: center;">K</td> <td style="text-align: center;">KN</td> <td style="text-align: center;">KS</td> </tr> <tr> <td>850F/455C</td> <td style="text-align: center;">M</td> <td style="text-align: center;">MN</td> <td style="text-align: center;">MS</td> </tr> <tr> <td>900F/480C</td> <td style="text-align: center;">N</td> <td style="text-align: center;">NN</td> <td style="text-align: center;">NS</td> </tr> <tr> <td>950F/510C</td> <td style="text-align: center;">Q</td> <td style="text-align: center;">QN</td> <td style="text-align: center;">QS</td> </tr> <tr> <td>1000F/540C</td> <td style="text-align: center;">R</td> <td style="text-align: center;">RN</td> <td style="text-align: center;">RS</td> </tr> <tr> <td>1050F/565C</td> <td style="text-align: center;">S</td> <td style="text-align: center;">SN</td> <td style="text-align: center;">SS</td> </tr> <tr> <td>1100F/595C</td> <td style="text-align: center;">T</td> <td style="text-align: center;">TN</td> <td style="text-align: center;">TS</td> </tr> <tr> <td>Other</td> <td style="text-align: center;">Z</td> <td style="text-align: center;">ZN</td> <td style="text-align: center;">ZS</td> </tr> </table>		Steam and Continuous	Intermittent Add 'N' to temperature designation	One Minute MAX Add 'S' to temperature designation (020730)	450F/230C	A	AN	AS	500F/260C	B	BN	BS	550F/290C	C	CN	CS	600F/315C	D	DN	DS	650F/345C	F	FN	FS	700F/370C	G	GN	GS	750F/400C	J	JN	JS	800F/425C	K	KN	KS	850F/455C	M	MN	MS	900F/480C	N	NN	NS	950F/510C	Q	QN	QS	1000F/540C	R	RN	RS	1050F/565C	S	SN	SS	1100F/595C	T	TN	TS	Other	Z	ZN	ZS
	Steam and Continuous	Intermittent Add 'N' to temperature designation	One Minute MAX Add 'S' to temperature designation (020730)																																																														
450F/230C	A	AN	AS																																																														
500F/260C	B	BN	BS																																																														
550F/290C	C	CN	CS																																																														
600F/315C	D	DN	DS																																																														
650F/345C	F	FN	FS																																																														
700F/370C	G	GN	GS																																																														
750F/400C	J	JN	JS																																																														
800F/425C	K	KN	KS																																																														
850F/455C	M	MN	MS																																																														
900F/480C	N	NN	NS																																																														
950F/510C	Q	QN	QS																																																														
1000F/540C	R	RN	RS																																																														
1050F/565C	S	SN	SS																																																														
1100F/595C	T	TN	TS																																																														
Other	Z	ZN	ZS																																																														
	Type of bundle/tracer E = electric L = light steam trace H = heavy steam trace																																																																
#	Number of process tubes 1 = one process tube 2 = two process tubes																																																																
X	Jacket Material S = SV47-O'Brien PVC U = TPU																																																																
-	Separator																																																																
XX	Process tube material, construction & wall thickness See Tube List																																																																
##	Process tube size in 1/8" or mm																																																																
- XX	Separator																																																																
##	Tracer – electric tracer family or steam tube material, construction & wall thickness																																																																
Options Listing (Repeat as necessary)	Electric output in w/ft or steam tube size in 1/8" or mm																																																																
/																																																																	
X	Separator between each option – repeat as necessary																																																																
	Jacket Color A = gray (formerly known as "GY" (4/3/03)) R = red B = blue G = green Y = yellow W = white P = purple N = orange U = brown																																																																
X##	Temperature sensor J = J- thermocouple K = K-thermocouple T = T-thermocouple R= 100W / 100PT 3 wire RTD XX = distance from power end in units of measure																																																																
####	Specials identifier – if "Z" is used in model number																																																																

TRACEPAK Model Number

TPEElectric Traced
TPHHeavy Steam Traced
TPLLight Steam Traced
TPSPreinsulated Tubing
1 or 2Number of Process Tubes
S or UJacket Material, **S** = SV47, **U** = TPU
Tube DesignationProcess Tube Selection
Tube or Tracer DesignationTracer Selection

Example:

O'Brien Model **TPE2S-F4-B5**

Electric traced bundle with SV47 jacket and two
1/2" x 0.035 wall 316SS Seamless process tubes
and a 5 watt/ft high temperature tracer.

S-Line Model Number

SProduct Designation
Tube DesignationProcess Tube Selection

Example:

O'Brien Model **SA4**

Preinsulated 1/2" x 0.035 wall welded 316ss with
SV47 jacket

TUBING SPECIFICATIONS

Designation	Material	Construction	OD	Wall	Max. Pressure*	Max. Continuous Length Possible**	Specifications
F1	316/316L SS	Seamless	1/8"	0.035"	10,900 psig	900 ft	A269, A213-EAW
F2	316/316L SS	Seamless	1/4"	0.035"	5,100	2,200	A269, A213-EAW
F3	316/316L SS	Seamless	3/8"	0.035"	3,300	1,300	A269, A213-EAW
F4	316/316L SS	Seamless	1/2"	0.035"	2,600	1,000	A269, A213-EAW
B2	316/316L SS	Seamless	1/4"	0.049"	7,500	1,300	A269, A213-EAW
B3	316/316L SS	Seamless	3/8"	0.049"	4,800	1,000	A269, A213-EAW
B4	316/316L SS	Seamless	1/2"	0.049"	3,700	750	A269, A213-EAW
BH3	316/316H SS	Seamless	3/8"	0.049"	5,100	490	A213
BH4	316/316H SS	Seamless	1/2"	0.049"	3,800	350	A213
BW3	316/316L SS	Seamless	3/8"	0.049"	5,700	450	A213
BW4	316/316L SS	Seamless	1/2"	0.049"	4,200	650	A213
K4	316/316L SS	Seamless	1/2"	0.065"	5,100	250	A269, A213-EAW
B6	316/316L SS	Seamless	3/4"	0.049"	3,500	250	A269, A213-EAW
A2	316/316L SS	Welded	1/4"	0.035"	4,080	2,500	A269
A3	316/316L SS	Welded	3/8"	0.035"	2,640	2,500	A269
A4	316/316L SS	Welded	1/2"	0.035"	2,080	2,000	A269
E4	316/316L SS	Welded	1/2"	0.049"	2,975	1,000	A269
N2	Monel	Seamless	1/4"	0.035"	4,800	1,000	B163, B165
N3	Monel	Seamless	3/8"	0.035"	3,100	600	B163, B165
P4	Monel	Seamless	1/2"	0.049"	3,210	600	B163, B165
J2	Copper	Seamless	1/4"	0.030"	1,400	2,600	B68, B75
C3	Copper	Seamless	3/8"	0.032"	900	2,000	B68, B75
D4	Copper	Seamless	1/2"	0.035"	800	1,000	B68, B75
M4	Copper	Seamless	1/2"	0.049"	1,100	1,000	B68, B75
M6	Copper	Seamless	3/4"	0.049"	725	500	B68, B75
G2	PFA Teflon	Extruded	1/4"	0.030"	155	1,000	
G3	PFA Teflon	Extruded	3/8"	0.030"	95	1,000	
H4	PFA Teflon	Extruded	1/2"	0.062"	155	1,000	

Tubing Metric

Designation	Material	Construction	OD	Wall	Max. Pressure*	Max. Continuous Length Possible**	Specifications
MF6	316/316L SS	Seamless	6mm	1mm	460 Bar	300M	A269, A213-EAW, DIN 17458 1.4401/1.4404
MF8	316/316L SS	Seamless	8mm	1mm	330	210	A269, A213-EAW, DIN 17458 1.4401/1.4404
MF10	316/316L SS	Seamless	10mm	1mm	260	165	A269, A213-EAW, DIN 17458 1.4401/1.4404
MF12	316/316L SS	Seamless	12mm	1mm	210	150	A269, A213-EAW, DIN 17458 1.4401/1.4404
MB10	316/316L SS	Seamless	10mm	1.5mm	410	150	A269, A213-EAW, DIN 17458 1.4401/1.4404
MB12	316/316L SS	Seamless	12mm	1.5mm	330	120	A269, A213-EAW, DIN 17458 1.4401/1.4404
MD6	Copper	Seamless	6mm	1mm		95	600 B68, B75
MD8	Copper	Seamless	8mm	1mm		60	455 B68, B75
MD12	Copper	Seamless	12mm	1mm		55	300 B68, B75
MG6	PFA Teflon	Extruded	6mm	1mm		10	300
MG8	PFA Teflon	Extruded	8mm	1mm		8	300
MG10	PFA Teflon	Extruded	10mm	1mm	7	300	
MG12	PFA Teflon	Extruded	12mm	1mm	4	300	
MA12	316/316L SS	Welded	12mm	1mm	170	300	ASTM, A269

*Maximum Pressure @ 72F (23C) Values calculated using S values as specified for metallic tube in ANSI B31.3 code.

** Consult Factory for availability of longer continuous lengths.

Pressure Correction Factors

	PFA Teflon	Copper	316SS	Monel
200F (93C)	0.84	0.80	1.00	0.88
400F (204C)	0.30	0.50	0.95	0.79
600F (316C)	-	-	0.82	0.79
800F (427C)	-	-	0.79	0.7

TrueTube™

Designation	Material	Construction	OD	Wall	Max. Pressure*	Max. Continuous Length Possible**	Specifications
TC1	Electropolished 316/316L SS	Seamless	1/8"	0.035"	10,900 psig	100 ft	A269, A213-EAW
TE2	Electropolished 316/316L SS	Seamless	1/4"	0.035"	5,100	300	A269, A213-EAW
TE3	Electropolished 316/316L SS	Seamless	3/8"	0.035"	3,300	300	A269, A213-EAW
TE4	Electropolished 316/316L SS	Seamless	1/2"	0.035"	2,600	300	A269, A213-EAW
TG4	Electropolished 316/316L SS	Seamless	1/2"	0.049"	2,600	300	A269, A213-EAW
TB1	Chemically Polished with Fused Silica ID Coating 316/316L SS	Seamless	1/8"	0.035"	10,900	100	A269, A213-EAW
TF2	Chemically Polished with Fused Silica ID Coating 316/316L SS	Seamless	1/4"	0.035"	5,100	300	A269, A213-EAW
TF3	Chemically Polished with Fused Silica ID Coating 316/316L SS	Seamless	3/8"	0.035"	3,300	300	A269, A213-EAW
TF4	Chemically Polished with Fused Silica ID Coating 316/316L SS	Seamless	1/2"	0.035"	2,600	300	A269, A213-EAW
TH4	Chemically Polished with Fused Silica ID Coating 316/316L SS	Seamless	1/2"	0.049"	2,600	300	A269, A213-EAW
TD1	Electropolished with Sulfinert 316/316L SS	Seamless	1/8"	0.035"	10,900	100	A269, A213-EAW
TS2	Electropolished with Sulfinert 316/316L SS	Seamless	1/4"	0.035"	5,100	300	A269, A213-EAW
TS3	Electropolished with Sulfinert 316/316L SS	Seamless	3/8"	0.035"	3,300	300	A269, A213-EAW
TS4	Electropolished with Sulfinert 316/316L SS	Seamless	1/2"	0.035"	2,600	300	A269, A213-EAW
TJ4	Electropolished with Sulfinert 316/316L SS	Seamless	1/2"	0.049"	2,600	300	A269, A213-EAW

TrueTube™ Metric

Designation	Material	Construction	OD	Wall	Max. Pressure*	Max. Continuous Length**	Specifications
MTE6	Electropolished, 316/316L SS	Seamless	6mm	1mm	460 Bar	30M	A269, A213-EAW, DIN 17458 1.4401/1.4404
MTE8	Electropolished, 316/316L SS	Seamless	8mm	1mm	330	100	A269, A213-EAW, DIN 17458 1.4401/1.4404
MTE10	Electropolished, 316/316L SS	Seamless	10mm	1mm	260	100	A269, A213-EAW, DIN 17458 1.4401/1.4404
MTG10	Electropolished, 316/316L SS	Seamless	10mm	1.5mm	410	100	A269, A213-EAW, DIN 17458 1.4401/1.4404
MTE12	Electropolished, 316/316L SS	Seamless	12mm	1mm	210	100	A269, A213-EAW, DIN 17458 1.4401/1.4404
MTG12	Electropolished, 316/316L SS	Seamless	12mm	1.5mm	330	100	A269, A213-EAW, DIN 17458 1.4401/1.4404
MTF6	Chemically Polished with Fused Silica ID Coating, 316/316L SS	Seamless	6mm	1mm	460	30	A269, A213-EAW, DIN 17458 1.4401/1.4404
MTF8	Chemically Polished with Fused Silica ID Coating, 316/316L SS	Seamless	8mm	1mm	330	100	A269, A213-EAW, DIN 17458 1.4401/1.4404
MTF10	Chemically Polished with Fused Silica ID Coating, 316/316L SS	Seamless	10mm	1mm	260	100	A269, A213-EAW, DIN 17458 1.4401/1.4404
MTH10	Chemically Polished with Fused Silica ID Coating, 316/316L SS	Seamless	10mm	1.5mm	410	100	A269, A213-EAW, DIN 17458 1.4401/1.4404
MTF12	Chemically Polished with Fused Silica ID Coating, 316/316L SS	Seamless	12mm	1mm	210	100	A269, A213-EAW, DIN 17458 1.4401/1.4404
MTH12	Chemically Polished with Fused Silica ID Coating, 316/316L SS	Seamless	12mm	1.5mm	330	100	A269, A213-EAW, DIN 17458 1.4401/1.4404
MTS6	Electropolished with Sulfinert ID Coating 316/316L SS	Seamless	6mm	1mm	460	30	A269, A213-EAW, DIN 17458 1.4401/1.4404
MTS8	Electropolished with Sulfinert ID Coating 316/316L SS	Seamless	8mm	1mm	330	100	A269, A213-EAW, DIN 17458 1.4401/1.4404
MTS10	Electropolished with Sulfinert ID Coating 316/316L SS	Seamless	10mm	1mm	260	100	A269, A213-EAW, DIN 17458 1.4401/1.4404
MTJ10	Electropolished with Sulfinert ID Coating 316/316L SS	Seamless	10mm	1.5mm	410	100	A269, A213-EAW, DIN 17458 1.4401/1.4404
MTS12	Electropolished with Sulfinert ID Coating 316/316L SS	Seamless	12mm	1mm	210	100	A269, A213-EAW, DIN 17458 1.4401/1.4404
MTJ12	Electropolished with Sulfinert ID Coating 316/316L SS	Seamless	12mm	1.5mm	330	100	A269, A213-EAW, DIN 17458 1.4401/1.4404

HEATER SPECIFICATIONS

Electric Heater Data

Low Temperature Tracers with Fluoropolymer Overjacket

Code	V	W/ft	W/m	Max. Maint. and Exposure	Max. Inter. Exposure	T-Rating	Connection Kits		Approvals
							Power	Termination	
J5	120	5	-	150F (65C)	185F (85C)	T6	T210-PC T210-PC or TPC1	T210-ET T210-ET or TPC1	FM Appvd. Cl I, II, III Div. 2, Gr. B, C, D, E, F, G CSA Cert. Cl I, II Div. 1, 2, Gr. A, B, C, D, E, F, G
J8	120	8	-	150F (65C)	185F (85C)	T6	T210-PC T210-PC or TPC1	T210-ET T210-ET or TPC1	FM Appvd. Cl I, II, III Div. 2, Gr. B, C, D, E, F, G CSA Cert. Cl I, II Div. 1, 2, Gr. A, B, C, D, E, F, G
J10	120	10	-	150F (65C)	185F (85C)	T6	T210-PC T210-PC or TPC1	T210-ET T210-ET or TPC1	FM Appvd. Cl I, II, III Div. 2, Gr. B, C, D, E, F, G CSA Cert. Cl I, II Div. 1, 2, Gr. A, B, C, D, E, F, G
P5	240	5	16	150F (65C)	185F (85C)	T6	T210-PC T210-PC or TPC1 T9310-PC	T210-ET T210-ET or TPC1 T310-ET10	FM Appvd. Cl I, II, III Div. 2, Gr. B, C, D, E, F, G CSA Cert. Cl I, II Div. 1, 2, Gr. A, B, C, D, E, F, G GENELEC EEx e II T6
P8	240	8	25	150F (65C)	185F (85C)	T6	T210-PC T210-PC or TPC1 T9310-PC	T210-ET T210-ET or TPC1 T310-ET10	FM Appvd. Cl I, II, III Div. 2, Gr. B, C, D, E, F, G CSA Cert. Cl I, II Div. 1, 2, Gr. A, B, C, D, E, F, G GENELEC EEx e II T6
P10	240	10	32	150F (65C)	185F (85C)	T6	T210-PC T210-PC or TPC1 T9310-PC	T210-ET T210-ET or TPC1 T310-ET10	FM Appvd. Cl I, II, III Div. 2, Gr. B, C, D, E, F, G CSA Cert. Cl I, II Div. 1, 2, Gr. A, B, C, D, E, F, G GENELEC EEx e II T6

High Temperature Tracers with Fluoropolymer Overjacket

Code	V	W/ft	W/m	Max. Maintain and Exposure	Max. Intermittent Exposure	T-Rating	Connection Kits		Approvals
							Power	Termination	
B5	120	5	-	250F (120C)	420F (215C)	T3	T210-PC T210-PC or TPC1	T210-ET T210-ET or TPC1	FM Appvd. Cl I, II, III Div. 2, Gr. A, B, C, D, E, F, G CSA Cert.. Cl I, II, III Div. 1, 2, Gr. A, B, C, D, E, F, G
B10	120	10	-	250F (120C)	420F (215C)	T3	T210-PC T210-PC or TPC1	T210-ET T210-ET or TPC1	FM Appvd. Cl I, II, III Div. 2, Gr. A, B, C, D, E, F, G CSA Cert.. Cl I, II, III Div. 1, 2, Gr. A, B, C, D, E, F, G
B15	120	15	-	250F (120C)	420F (215C)	T2D	T210-PC T210-PC or TPC1	T210-ET T210-ET or TPC1	FM Appvd. Cl I, II, III Div. 2, Gr. A, B, C, D, E, F, G CSA Cert.. Cl I, II, III Div. 1, 2, Gr. A, B, C, D, E, F, G
B20	120	20	-	250F (120C)	420F (215C)	T2D	T210-PC T210-PC or TPC1	T210-ET T210-ET or TPC1	FM Appvd. Cl I, II, III Div. 2, Gr. A, B, C, D, E, F, G CSA Cert.. Cl I, II, III Div. 1, 2, Gr. A, B, C, D, E, F, G
N5	240	5	15	250F (120C)	420F (215C)	T3	T210-PC T210-PC or TPC1 T9310-PC	T210-ET T210-ET or TPC1 T310-ET13	FM Appvd. Cl I, II, III Div. 2, Gr. A, B, C, D, E, F, G CSA Cert.. Cl I, II, III Div. 1, 2, Gr. A, B, C, D, E, F, G GENELEC EEx e II T3
N10	240	10	30	250F (120C)	420F (215C)	T3	T210-PC T210-PC or TPC1 T9310-PC	T210-ET T210-ET or TPC1 T310-ET13	FM Appvd. Cl I, II, III Div. 2, Gr. A, B, C, D, E, F, G CSA Cert.. Cl I, II, III Div. 1, 2, Gr. A, B, C, D, E, F, G GENELEC EEx e II T3
N15	240	15	47	250F (120C)	420F (215C)	T3	T210-PC T210-PC or TPC1 T9310-PC	T210-ET T210-ET or TPC1 T310-ET13	FM Appvd. Cl I, II, III Div. 2, Gr. A, B, C, D, E, F, G CSA Cert.. Cl I, II, III Div. 1, 2, Gr. A, B, C, D, E, F, G GENELEC EEx e II T3
N20	240	20	63	250F (120C)	420F (215C)	T2C	T210-PC T210-PC or TPC1 T9310-PC	T210-ET FM T210-ET or TPC1 T310-ET13	Appvd. Cl I, II, III Div. 2, Gr. A, B, C, D, E, F, G CSA Cert.. Cl I, II, III Div. 1, 2, Gr. A, B, C, D, E, F, G GENELEC EEx e II 240°C (T2)

Specialty Tracers

Code	V	W/ft	W/m	Max. Maintain and Exposure	Max. Intermittent Exposure	T-Rating	Connection Kits		Approvals
							Power	Termination	
JV10	120	10	-	400F (200C)	482F (250C)	T*	T250-PC T250-PC	T250-ET T250-ET	FM Appvd. Cl I, II, III Div. 2, Gr. B, C, D, E, F, G CSA Cert. Cl I, II Div. 2, Gr. A, B, C, D, E, F, G
JV20	120	20	-	300F (150C)	482F (250C)	T*	T250-PC T250-PC	T250-ET T250-ET	FM Appvd. Cl I, II, III Div. 2, Gr. B, C, D, E, F, G CSA Cert. Cl I, II Div. 2, Gr. A, B, C, D, E, F, G
JN10	240	10	30	400F (200C)	482F (250C)	T*	T250-PC T250-PC	T250-ET T250-ET	FM Appvd. Cl I, II, III Div. 2, Gr. B, C, D, E, F, G CSA Cert. Cl I, II Div. 2, Gr. A, B, C, D, E, F, G GENELEC EEx es II T*
JN20	240	20	60	300F (150C)	482F (250C)	T*	T250-PC T250-PC	T250-ET T250-ET	FM Appvd. Cl I, II, III Div. 2, Gr. B, C, D, E, F, G CSA Cert. Cl I, II Div. 2, Gr. A, B, C, D, E, F, G GENELEC EEx es II T*
T18	120	18	-	400F (200C)	450F (230C)	T*		T9G90-UC	Non-Hazardous Areas
TY18	208	18	-	400F (200C)	450F (230C)	T*		T9G90-UC	Non-Hazardous Areas
TN18	240	18	-	400F (200C)	450F (230C)	T*		T9G90-UC	Non-Hazardous Areas

T* - established by application

CONNECTION KITS

Detailed installation instructions are included with each kit.



T210-PC

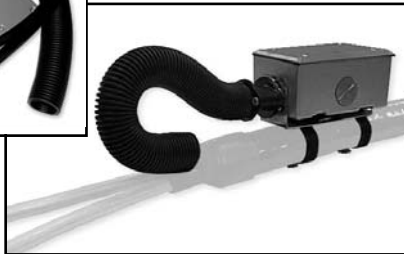

- FM Approved and CSA Certified Class I Div. 2 termination kit for use with any wattage B, N, J, or P tracer. Includes junction box and bundle mounting bracket with adjustable straps. Junction box also includes surface mounting feet.



T9310-PC



- Approved to CENELEC standards for hazardous area locations. Use with any wattage P and N tracers. Installs in customer supplied junction box with M25 hub.



TPC1

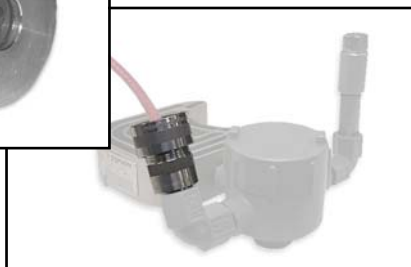

- CSA Certified Class I Div. 1 power connection or end termination kit for use with any wattage B, J, N, or P tracer. Installs in customer supplied junction box with 1/2" npt hub.

TERMINATION KITS



T210-ET



- FM Approved and CSA Certified Class I Div. 2 termination kit for use with any wattage B, N, J, or P tracer.



T310-ET10

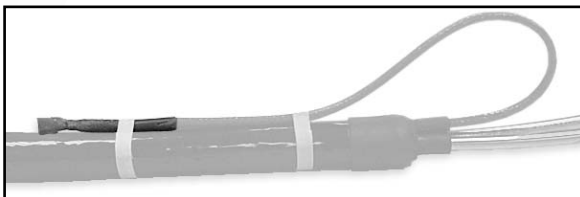

- Approved to CENELEC standards for hazardous area locations. Use with any wattage P tracer.



T310-ET13

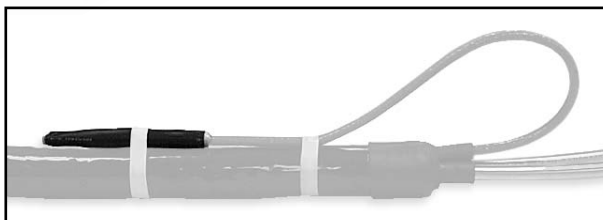

- Approved to CENELEC standards for hazardous area locations. Use with any wattage MN and N tracers.

SEALING

TPKHS - Heat shrink boots

TPKHS is a series of heat-shrinkable end seal boots made of a thermally stabilized, modified polyolefin. They are designed to provide a weatherproof seal at the end of tubing bundles. These boots may be used for process temperatures up to 400°F (204°C).



TPKHS-E1

**Body dia.
Min/Max**
0.375"/1.30"
(9mm/33mm)

**Leg dia.
Min/Max**
—

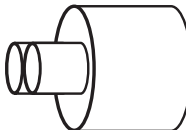

TPKHS-C2

0.95"/1.90"
(24mm/48mm)

0.30"/0.75"
(8mm/19mm)

TPKHS-D2

0.45"/1.60"
(11mm/40mm)

0.15"/0.55"
(4mm/14mm)

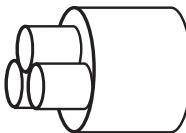

TPKHS-A3

1.40"/2.40"
36mm/60mm

0.50"/1.13"
12mm/28mm

TPKHS-B3

0.90"/1.70"
22mm/43mm

0.30"/0.80"
8mm/20mm

TPKHS Selection

Bundle Family	Process Tube	Tracer Tube Size	Model Number Size	Bundle Family	Process Tube	Tracer Tube Size	Model Number Size
S-LINE	1/4 (6mm)		*TPKHS-E1	TPH1	3/8 (8mm)	3/8 (8mm)	TPKHS-C2
	3/8 (8mm)		TPKHS-E1			1/2 (12mm)	TPKHS-C2
	1/2 (12mm)		TPKHS-E1		1/2 (12mm)	3/8 (8mm)	TPKHS-C2
TPL1	3/8 (8mm)	3/8 (8mm)	TPKHS-C2			1/2 (12mm)	TPKHS-C2
		1/2 (12mm)	TPKHS-C2	TPH2	3/8 (8mm)	3/8 (8mm)	TPKHS-B3
	1/2 (12mm)	3/8 (8mm)	TPKHS-C2		1/2 (12mm)	1/2 (12mm)	TPKHS-A3
TPL2	3/8 (8mm)	1/2 (12mm)	TPKHS-C2	TPE1	1/4 (6mm)		TPKHS-D2
		1/2 (12mm)	*TPKHS-A3		3/8 (8mm)		TPKHS-C2
	1/2 (12mm)	3/8 (8mm)	*TPKHS-A3	TPE2	1/4 (8mm)		*TPKHS-B3
		1/2 (12mm)	TPKHS-A3		3/8 (8mm)		TPKHS-B3
					1/2 (12mm)		TPKHS-B3

*Boot leg should be pinched with pliers while hot and held until cool to reduce leg diameter.

TPKES - Entry Seal

TPKES The heat-shrinkable entry seal provides a waterproof fitting where TRACEPAK enters an enclosure. They can be added to parting line or surface mounted plates on VIPAK enclosures or any enclosure. The thermally stabilized, modified polyolefin entry seal consists of an O-ring assembly that seals at the enclosure and a heat-shrinkable nose that seals to the TRACEPAK bundle.

TPKES Selection

* Different panel thickness than VIPAK ES options

Model Number	Max. Panel* Thickness (A)	Maximum I.D. Nose (B)	Minimum I.D. Nose (C)	Mounting Hole Diameter (D)
TPKES-4	0.50" (12mm)	1.60" (40mm)	0.75" (19mm)	2.00" (50mm)
TPKES-4S	1.00" (25mm)	2.10" (51mm)	0.75" (19mm)	2.38" (60mm)
TPKES-5	1.00" (25mm)	2.75" (70mm)	1.43" (36mm)	3.50" (89mm)
TPKES-6X	1.00" (25mm)	3.50" (89mm)	1.50" (40mm)	4.50" (114mm)

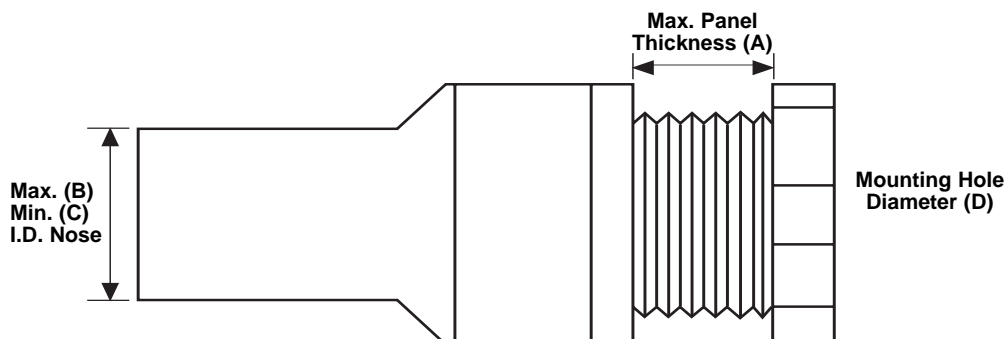

SEALING

TPKSK SILICONE SEALANT

O'Brien's RTV end sealant is a black adhesive/sealant which cures to a tough rubbery solid upon exposure to moisture in the air. The cure time is 24 hours at 77°F and (25°C) and a relative humidity of 50%. Its maximum service temperature extremes are -60°F to 450°F (-60°C to 210°C). It has excellent resistance to weather, oil, and many chemicals.

TPKSK-10 will seal approximately 10 bundle ends.

TPKJP-1, TPKJP-2 JACKET PATCH For process tube temperatures up to 400°F (204°C)

***If your tubing bundle has an innermost layer of woven glass insulation, use the High Temperature Jacket Patch Kit (TPKJP-3 or -4).**

O'Brien's Jacket Patch Kit is made up of thermal insulation, fiberglass tape to hold the insulation in place, and a black self-sealing rubber patch for weatherproofing the bundle. It is to be used to insulate an area where two bundles have been spliced together and the tubes connected with a tube fitting.

TPKJP-3, TPKJP-4 HIGH TEMPERATURE JACKET PATCH For process tube temperatures over 400°F (204°C)

O'Brien's High Temperature Jacket Patch Kit is made up of woven fiberglass insulation, fiberglass strip insulation, fiberglass adhesive tape to hold the insulation in place, and a black self-sealing rubber patch for weatherproofing the bundle. It is to be used to insulate an area where two high temperature bundles have been spliced together and the tubes connected with a tube fitting.

LINE SENSING THERMOSTAT

The temperature sensing bulb, RTD or thermocouple of the thermostat should be placed in direct contact with the process tube or tubes and not in contact with the electric tracer. Each thermostat is different and specific installation procedures may vary.

To install the line sensing thermostat:

- Locate a suitable mounting location for the thermostat housing. Route the capillary along the bundle away from heat sources other than the tracer in the bundle. (Do not place near process connection or the heater in an enclosure.)
- Locate the tracer in the bundle. The tracer can usually be felt through the bundle and insulation. Make a slit lengthwise along the bundle, opposite the tracer, where the capillary bulb will be placed. The slit should be about 2" (50mm) longer than the length of the bulb and it must go through the insulation and mylar.
- Insert the bulb in the bundle in direct contact with the process tube or tubes. Cut three pieces of the 2" (50mm) wide fiberglass insulating tape about 1" (25mm) less than the length of the slit. For each piece, fold the tape along the cut length making a double layer tape of 1" (25mm) wide. Work each of the three tapes into the slit covering the capillary bulb and under the jacket material.
- Use the fiberglass tape supplied with the jacket patch kit to wrap the bundle over the slit every 1½" (40mm). Secure the capillary to the bundle with the tape for a distance of at least 2" (50mm) from the end of the slit. Apply a liberal bead of sealant, similar to TPKSK, along each side of the capillary.
- Use the black rubber patch supplied with the jacket patch kit and wrap the bundle to seal the slit. Cut the black rubber patch so that it extends 2" (50mm) past the slit in both directions. Remove the protective backing and wrap it around the patch area, overlapping it, and press into place. Wire the switch to the power supply and the tracer per local and applicable codes.





BELGIUM • BRAZIL • CHINA • RUSSIA • SINGAPORE • SOUTH KOREA • USA
sales.obrien@ametek.com • www.obcorp.com

