

Tools & Materials

- 1-3/8" open end wrench
- 7/16" open end wrench
- (2) 7/8" open end wrenches
- 1-3/16" open end wrench

Additional Information

FITTINGS REQUIRED: Appropriate size female full port ball valve

Safety Warnings

 Failure to abide by any of the safety warnings or operation of this device outside the limits stated below may result in equipment failure and serious injury or death.

- Do not exceed any equipment pressure ratings.
- The probe must be installed into the process line by means of the appropriate size FNPT full port ball valve.
- Use the wrench flats on the base (not the packing gland nut) when installing into the process ball valve.
- The wrench flats on the threaded rod must be used when lowering or raising the probe after it is installed.
- Do not use the wrench flats on the packing gland nut, located above the base, for any installation purposes.
- This product is maintained. The user should follow company safety practices concerning Personal Protective Equipment (PPE) as well as any and all OSHA, state and local regulations.
- Do not use regulator as a shut off device.

Model Identification

(755-Cartridge)



U.S. Patents 8,522,630; 9,200,986



An ISO 9001:2015 certified company

Technical Specifications

Technical Specifications

Maximum Pressure Rating	NPT: 3,750 psig (258.6 barg)
Temperature Ranges	Type 6 membranes: -35°F (-37°C) to 185°F (85°C) *Type 7 membrane: Up to 300°F (149°C) <small>* Actual limit depends on sealing material chosen. Refer to Temperature Range Comparison Chart.</small>
Port Sizes	Outlet: 1/4" female NPT Auxiliary: 1/8" female NPT (plugged from factory)
Probe Lengths	L: 8", 12", 18", 24", 36", 48" A: ~ 20", 24", 30", 36", 48", 60" (refer to L & A dimensions on back)
Outlet Pressure Range psig (barg)	0-10 (0-0.7), 0-25 (0-1.7), 0-50 (0-3.4), 0-100 (0-6.9), 0-250 (0-17.2), 0-500 (0-35.4)
Process Connection Requirement	3/4", 1" or 1.5" NPT full opening threaded or flanged valve Ball, gate and double block and bleed valves are all suitable for use as long as their inner diameter is not less than 3/4". 1" NPT or larger process connection required for seal welding.
Wetted Materials For Silcotek [™] coatings, contact the factory.	Machined parts: 316/316L stainless steel / ISO 15156-3 compliant and Kevlar [®] threaded bushing All other metal parts: stainless steel / ISO 15156-3 compliant Sealing material: User defined Regulator seat material: PFA Membrane: inert

Maximum Recommended Flow Rate
Dependant on source pressure. See chart.

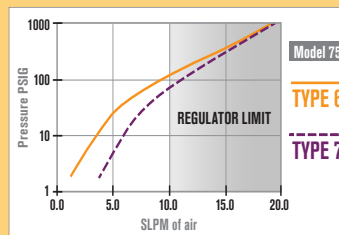

Overview Instructions & Explanations

1- Install into process valve

- 1.1 An optional valve may be installed on the 755 outlet. If installed, it should remain closed during insertion until the probe is fully installed.
- 1.2 Apply a thread sealant, such as Teflon[®] Tape, to the male threads on the bottom of the probe. (Nickel-infused is recommended.)

2- Optional line pressure gauge installation

- 2.1 Remove NPT plug labeled gauge/vent and install line pressure gauge if desired.

3- Pressurize the probe

- 3.1 Rotate the regulator pressure adjustment screw counter clockwise only until it rotates freely.
- 3.2 Close the ball valve on the regulator outlet, if so equipped.
- 3.3 Slowly open the 3/4" ball valve to the process. (see Figure 2)

Figure 1

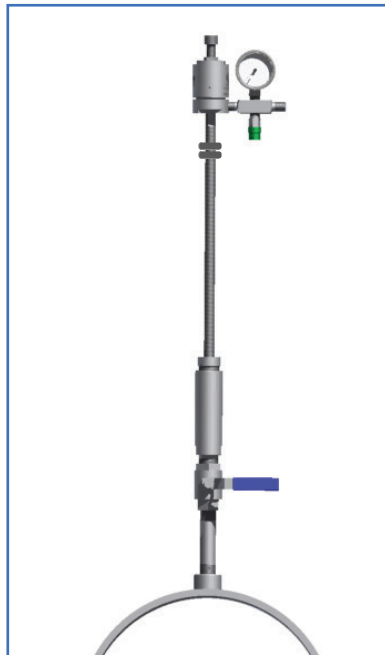

Figure 2



(continued)



Overview Instructions & Explanations

4- Lowering the probe to proper insertion depth

- 4.1 Note your insertion depth (D1) and measure that distance from top of the probe body to that point on the rack. (Figures 3&4)
- 4.2 Thread the 2 depth marking nuts on the threaded rod to the predetermined lower stopping point. Using 2 7/8" open end wrenches, rotate the upper nut clockwise and the lower nut counterclockwise until the nuts are locked firmly in place.
- 4.3 Lower the probe to the proper depth by using a 7/16" open end wrench or optional speed wrench (Part ACC-SW) only on the wrench flats of the threaded rod of the probe. (Figure 5)

Figure 3

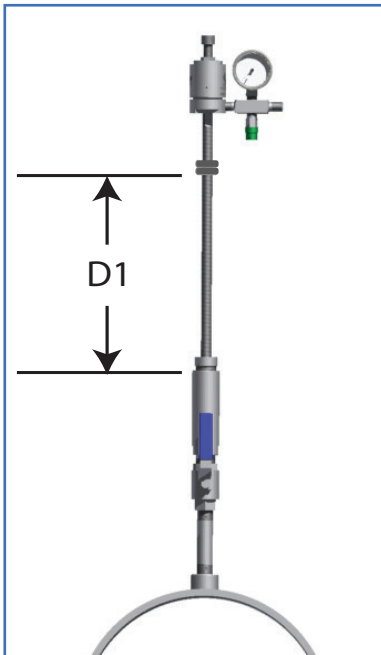

Figure 4

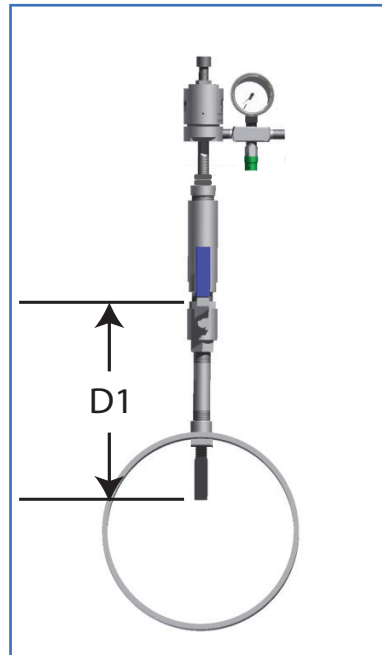

Figure 5



(continued)



Overview Instructions & Explanations

5- Leak testing the probe connections

- 5.1 Using a leak detector, check for leaks at the following locations: probe outlet to the closed customer supplied ball valve, process connection, probe packing gland nut, and additionally any other connection made during the probe installation.
- 5.2 If leaking occurs through the probe packing gland, use a 1 3/16" open end wrench to tighten the packing gland nut until the leak stops. **DO NOT OVERTIGHTEN.**
- 5.3 The amount of torque required to seal the packing gland will vary with process conditions and the sealing material. Seals with higher durometer require significantly more torque than lower durometer seals. These seals, at higher pressure, may require as much as 80 ft-lbs of torque to produce a leak tight seal. This table (below) shows the durometer hardness of elastomers available for Genie[®] Direct Drive[™] Probes.
- 5.4 Be aware that the packing gland nut may need to be tightened periodically as conditions change or as the packing material wears during insertion/retraction.

6- Setting outlet pressure

- 6.1 Once sample transport tubing has been connected to the probe/probe regulator outlet, the sample pressure can be adjusted to the desired value. This is accomplished by turning the pressure adjustment screw clockwise. To allow sample flow, slowly open external valving.
- 6.2 At high supply pressure, a sudden change may be observed on the downstream pressure gauge as the valve stem moves away from the seat. Slight readjustments may be necessary until the pressure and flow have equilibrated.
- 6.3 Tighten the pressure adjustment screw lock nut firmly against the washer to prevent unintended changes in pressure adjustment.

20 ft-lbs of torque [MIN]
LOWER DUROMETER
Neoprene
Fluoroelastomer (FKM) Perfluoroelastomer (FFKM)
RGD resistant HNBR
RGD resistant HNBR 985 FKM Compound VG109-90 Peroxide Cured Buna
HIGHER DUROMETER
80 ft-lbs of torque [MAX]





GENIE® 755

Direct Drive Probe™

Model Identification

Model Numbering & Additional Part Numbers

Your model number is determined by your specific needs. Choose options below.

Sealing material	0 = Neoprene rubber	J = RGD resistant HNBR	(other materials available upon request)			
Membrane type	6 = Better Rejection; Rejects ALL types of liquids from vapor					
	7 = Highest Temps; Rejects ONLY high surface tension liquids					
Process connection	3 = 3/4" NPT	4 = 1" NPT	6 = 1.5" NPT			
Outlet pressure range (psig)	00 = 0-25	01 = 0-50	02 = 0-100	03 = 0-250	P4 = 0-500	09 = 0-10
Regulator outlet port	1 = 1/4" MNPT to 1/8" tube connector			4 = 1/4" FNPT		
Probe insertion length (L)	8, 12, 18, 24, 36, 48 inches					

How to build the model number:

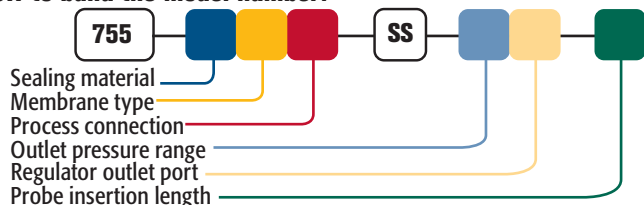

Spare Parts & Accessories (sold separately)

- Sealing material replacement (packing gland)
Part # 75X-570 for PTFE/Neoprene rubber
Part # 75X-5J0 for RGD resistant HNBR
- Complete membrane assembly replacement
Part # 75X-CMA-506 (contains 1 complete assembly)
- Regulator seat cartridge assembly replacement- Part # 755-7_1SS
(Use for serial #48766 and greater. Contact factory for others.)
- Speed Wrench for faster installation- Part # ACC-SW
- Manifold with pressure gauge, ball valve, & relief valve - for ordering information, refer to the Genie Probe Regulator Accessory Manifold product sheet
- KOZY insulated probe and valve covers- for ordering information, refer to the KOZY Assemblies product sheet



4, rue des Roses - 69280 SAINTE-CONSORCE - France
Tel: +33 478 878 945 - info@soclema.com - www.soclema.com



An ISO 9001:2015 certified company

Genie® Direct Drive Probe™, and Genie® Membrane Technology™ are trademarks or registered trademarks of A+ Corporation, LLC. All other referenced trademarks are the property of their respective owners.